

Synchronorm Showserver V3 U8

With the 19" installation model of Synchronorm Showserver V3 U8, it is possible to play real time multimedia shows which have been created within Depence. The server saves any number of shows with music on its 60GB hard disk which can be played to the second and can be controlled via the internal event scheduler. Up to 4 DMX universes (2048 DMX channels) direct or 8 universes (4096 DMX channels) over ArtNet can be controlled with one server and up to 32 servers can be operated in total. Via synchronization interfaces (SMPTE, NetTimecode, MTC, SNTC) the Showserver can synchronize other devices or can be synchronized by them. Furthermore, the device can also be controlled as a fixture via a DMX start address of lighting control desks. We also offer a huge number of simple text commands, which can be transmitted to the server via network or by direct entry.

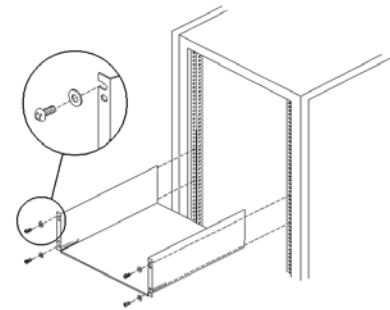

Technical details:

Dimensions (L x W x H):	482 x 360 x 130 mm
Weight:	12 kg
Housing:	19" Rack
Protection class:	IP20
Power supply:	ca. 500W 110/240Vac
Operation temperature:	0..40°C / 0..80% humidity non-condensed
Certification:	CE
Outputs:	4 x DMX-RDM (Neutrik XLR-5Pin, optically isolated) 2048 DMX channels 8 x DMX-RDM (over ArtNet) 4096 DMX channels 1 x balanced audio (2 x symmetrical XLR) 1 x DVI-I (with RGB for VGA Adapter), 1 x DVI-D (no RGB, no VGA) 2 x USB 2.0 2 x RJ45 10/100MBit Several Time Codes (SMPTE, Synchronorm Timecode, NetTimecode) Modbus via TCP / IP Network Livepage and Systemoverview over Monitor (optional)
Inputs:	1 x DMX-RDM (Neutrik XLR-5Pin, optically isolated) 512 DMX channels Sensor Connection (Wind-, Water Level, etc.) Several Time Codes (SMPTE, Synchronorm Timecode, NetTimecode)
Memory:	Solid state drive 60GB
Operation:	4 x 40 Segment LCD Display with 5 keys

In the scope of delivery:

- Hardware
- System Documentation





Showserver V3 U8 (back)

- A: 4 x DMX-RDM Output (Neutrik XLR-5Pin)
- B: 1 x DMX Input (Neutrik XLR-5Pin)
- C: SMPTE Output
- D: Power 110/240 VAC
- E: 1 x balanced Audio Output (2 x symmetrical XLR)
- F: Ethernet RJ45 10/100 MBit
- G: USB 2.0
- H: RS232
- I: 1 x DVI-I, 1 x DVI-D

Showserver V3 U8 (front)

- J: Ethernet RJ45 10/100 MBit
- K: USB 2.0

Connection examples

default:

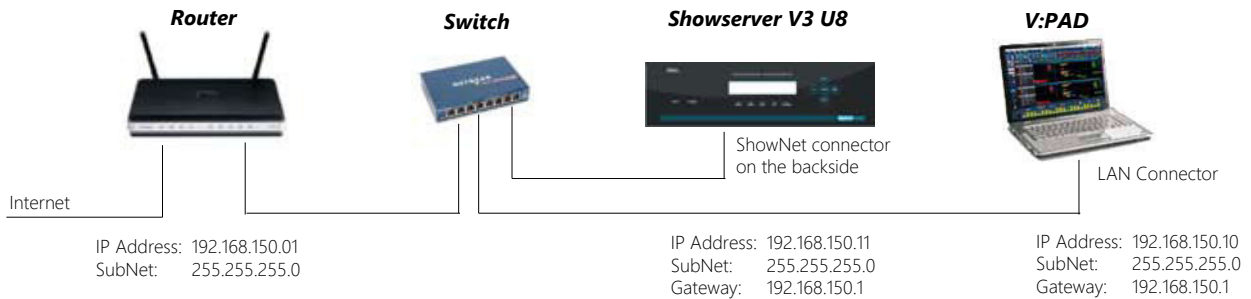

enhanced:

